

Noppenmatten
Feinriefenmatten
Anti-Rutsch-Matten
Isoliermatten
Leistenmatten
Breitriefenmatten
Ringmatten
Hammerschlagmatten
Gummiplatten
Para- und Verschleißschutzplatten
Kombiplatten
Gewebtreibriemen
Förderbänder
Wellenkanten
Sonderdichtungsplatten
Rampenpuffer
Standardformteile



Ihr Weg zur chinesischen
Gummi-Industrie

Sinoda

Industriegummi GmbH

Noppenmatten

Stud-Flooring

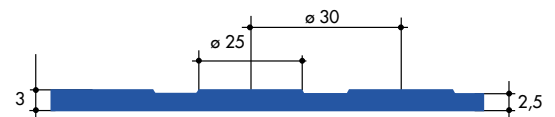
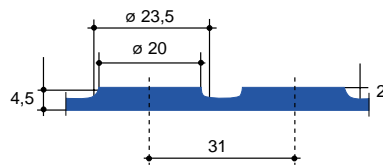

Typ Type	Qualität Quality	Spezifisches Gewicht Specific Gravity	Reißfestigkeit Tensile Strength	Reißdehnung Elongation	Härte Hardness	Temperatur Temperature
A- Standard Standard	NR/SBR	1,40 – 1,45 g/cm ³	ca. 7,5 MPa	ca. 280 %	80 ± 5 Shore A	ca. - 20 / + 90 °C
B- Ölbeständig Oil-resistant	NBR/SBR	1,40 – 1,45 g/cm ³	ca. 7,5 MPa	ca. 280 %	80 ± 5 Shore A	ca. - 20 / + 100 °C
Einsatzbereich Application	<ul style="list-style-type: none"> – Bodenbeläge für Bahnhöfe, Flughafen und Halle – Bodenbelag im Zug, Bus, Transporter und Anhänger – Eingangsbereich und Laufbahn – Werkstätten 					
Art. Nr. Art. No.	3NM-		Beständigkeit Resistance			
			Typ A-Standard Type A-Standard		Typ B-Ölbeständig Type B-Oil-resistant	
Gesamtstärke Total Thickness	3,0 mm 4,0 mm	4,5 mm	Öl Oil	keine Empfehlung not recommended	gut good	
Farbe Colour	schwarz, grau, braun, rot, blau black, grey, brown, red, blue		Treibstoffe Fuel	keine Empfehlung not recommended	gut good	
Breite Width	1000 mm 1200 mm	1000 mm	Säure Acidity	keine Empfehlung not recommended	keine Empfehlung not recommended	
Länge Length	10 m 20 m	10 m	Lauge Alkaline	bedingt moderate	bedingt moderate	
Rückseite Back	stoffgemustert cotton impression		Alterung Aging	bedingt moderate	bedingt moderate	

Ausführung 1 Execution 1

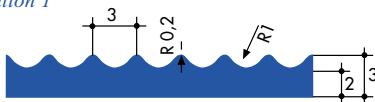

Ausführung 2 Execution 2



Feinriefenmatten

Fine Ribmatting



Typ Type	Qualität Quality	Spezifisches Gewicht Specific Gravity	Reißfestigkeit Tensile Strength	Reißdehnung Elongation	Härte Hardness	Temperatur Temperature
A- Standard Standard	NR/SBR	1,50 – 1,60 g/cm ³	ca. 3,8 MPa	ca. 200 %	65 ± 5 Shore A	ca. - 20 / + 70 °C
B- Ölbeständig Oil-resistant	NBR/SBR	1,40 – 1,50 g/cm ³	ca. 4,0 MPa	ca. 250 %	65 ± 5 Shore A	ca. - 20 / + 70 °C
Einsatzbereich Application	<ul style="list-style-type: none"> – Ablage für Regal und Arbeitstisch – Eingangsbereich und Laufbahn – Kabelabdeckungen bei Veranstaltungen – Werkstätten 					
Art. Nr. Art. No.	1FM-		Beständigkeit Resistance			
			Typ A-Standard Type A-Standard		Typ B-Ölbeständig Type B-Oil-resistant	
Gesamtstärke Total Thickness	2,5 mm 3,0 mm	4,0 mm	Öl Oil	keine Empfehlung not recommended	gut good	
Einlage Ply	ohne Einlage mit einer Einlage	without ply with 1 ply	Treibstoffe Fuel	keine Empfehlung not recommended	gut good	
Farbe Colour	schwarz, grau, grün black, grey, green		Säure Acidity	keine Empfehlung not recommended	keine Empfehlung not recommended	
Breite Width	1000 mm 1200 mm 1250 mm	1400 mm 1600 mm 1800 mm	Lauge Alkaline	bedingt moderate	bedingt moderate	
Länge Length	10 m 20 m		Alterung Aging	bedingt moderate	bedingt moderate	
Rückseite Back	stoffgemustert oder glatt cotton impression or smooth					

Leistenmatten

Wide Ribmatting



schwarz

Ausführung 1
Execution 1

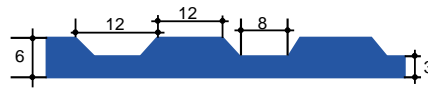

Ausführung 2
Execution 2

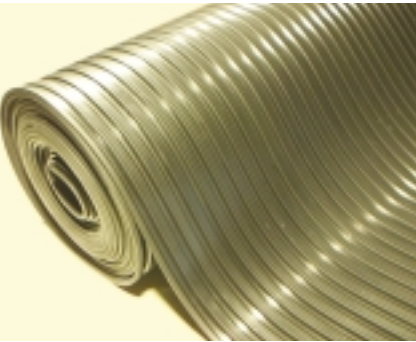
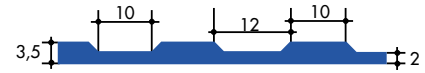

Typ Type	Qualität Quality	Spezifisches Gewicht Specific Gravity	Reißfestigkeit Tensile Strength	Reißdehnung Elongation	Härte Hardness	Temperatur Temperature
A- Standard Standard	NR/SBR	1,50 – 1,60 g/cm ³	ca. 5,5 Mpa	ca. 250 %	75 ± 5 Shore A	ca. - 20 / + 70 °C
B- Ölbeständig Oil-resistant	NBR/SBR	1,40 – 1,50 g/cm ³	ca. 5,0 Mpa	ca. 250 %	75 ± 5 Shore A	ca. - 20 / + 70 °C
Einsatzbereich Application	<ul style="list-style-type: none"> – Bodenbeläge für Bahnhof, Flughafen und Halle – Bodenbelag im Zug, Bus, Transporter und Anhänger – Eingangsbereich und Laufbahn – Werkstätten 			<ul style="list-style-type: none"> – flooring for railway station, airport and hall – flooring in train, bus, transporter and trailer – entrance and walking alley – workshops 		
Art. Nr. Art. No.	6LM-		Beständigkeit Resistance			
			Typ A-Standard Type A-Standard		Typ B-Ölbeständig Type B-Oil-resistant	
Gesamtstärke Total Thickness	3,5 mm		Öl Oil	keine Empfehlung not recommended	gut good	
	4,0 mm					
Farbe Colour	schwarz black		Treibstoffe Fuel	keine Empfehlung not recommended	gut good	
Breite Width	1400 mm		Säure Acidity	keine Empfehlung not recommended	keine Empfehlung not recommended	
	1600 mm					
	1800 mm					
	2000 mm					
Länge Length	10 m		Lauge Alkaline	bedingt moderate	bedingt moderate	
	10 m					
Rückseite Back	stoffgemustert oder glatt cotton impression or smooth		Alterung Aging	bedingt moderate	bedingt moderate	

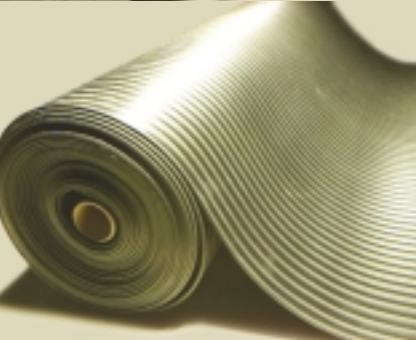
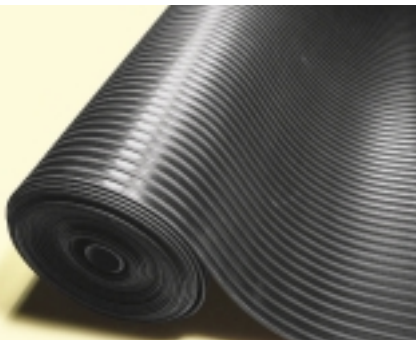

Breitriefenmatten

Wide Fine Ribmatting

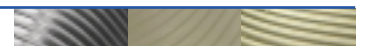

schwarz

grau

grün

Typ Type	Qualität Quality	Spezifisches Gewicht Specific Gravity	Reißfestigkeit Tensile Strength	Reißdehnung Elongation	Härte Hardness	Temperatur Temperature
A- Standard Standard	NR/SBR	1,50 – 1,60 g/cm ³	ca. 3,8 MPa	ca. 200 %	65 ± 5 Shore A	ca. - 20 / + 70 °C
B- Ölbeständig Oil-resistant	NBR/SBR	1,40 – 1,50 g/cm ³	ca. 4,5 MPa	ca. 250 %	65 ± 5 Shore A	ca. - 20 / + 70 °C
Einsatzbereich Application	<ul style="list-style-type: none"> – Bodenbeläge für Bahnhof, Flughafen und Halle – Eingangsbereich und Laufbahn – Kabelabdeckung bei Veranstaltungen – Werkstätten – Regal – Kegelbahn 			<ul style="list-style-type: none"> – flooring for railway station, airport and hall – entrance and walking alley – protective cover for cables in open area – workshops – shelves – bowling alley 		
Art. Nr. Art. No.	1BM-		Beständigkeit Resistance			
			Typ A-Standard Type A-Standard		Typ B-Ölbeständig Type B-Oil-resistant	
Gesamtstärke Total Thickness	3,0 mm		Öl Oil	keine Empfehlung not recommended	gut good	
	4,0 mm					
Farbe Colour	schwarz, grau, grün black, grey, green		Treibstoffe Fuel	keine Empfehlung not recommended	gut good	
Breite Width	1200 mm		Säure Acidity	keine Empfehlung not recommended	keine Empfehlung not recommended	
	10 m					
Länge Length	10 m		Lauge Alkaline	bedingt moderate	bedingt moderate	
	10 m					
Rückseite Back	stoffgemustert oder glatt cotton impression or smooth		Alterung Aging	bedingt moderate	bedingt moderate	

Ringmatten

Ring Matting

Sonderanfertigungen sind in rot, grün, grau oder braun sowie in ölbeständiger Qualität lieferbar.

Special finish like in red, green, grey, brown colour and oil-resistant quality are available.

Auch schwer-entflammbare Qualität nach DIN 4102/1.

Also fire resistant quality acc. to DIN 4102/1.

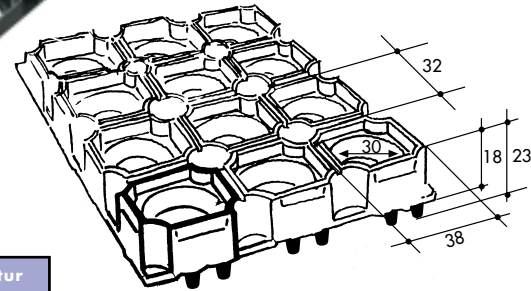

Typ Type	Qualität Quality	Spezifisches Gewicht Specific Gravity	Reißfestigkeit Tensile Strength	Reißdehnung Elongation	Härte Hardness	Temperatur Temperature
A- Standard Standard	NR/SBR	1,50 – 1,60 g/cm ³	ca. 4,5 MPa	ca. 250 %	65 ± 5 Shore A	ca. - 20 / + 70 °C
B- Ölbeständig Oil-resistant	NBR/SBR	1,40 – 1,50 g/cm ³	ca. 5,0 MPa	ca. 300 %	65 ± 5 Shore A	ca. - 20 / + 70 °C
Anwendung Application	<ul style="list-style-type: none"> – Innen- und Außen-Bereich – Eingangsbereich, Laufzone – Werkstätten, Baustellen – glatte, ölige und nasse Böden <ul style="list-style-type: none"> – indoor and outdoor – entrance, walking area – workshops, construction site – smooth, oily and wet floor 					
Art. Nr. Art. No.	4RM-		Beständigkeit Resistance			
			Typ A-Standard Type A-Standard	Typ B-Ölbeständig Type B-Oil-resistant		
Gesamtstärke Total Thickness	18 mm 23 mm		Öl Oil	keine Empfehlung not recommended	gut good	
Farbe Colour	schwarz, grau, grün black, grey, green		Treibstoffe Fuel	keine Empfehlung not recommended	gut good	
Format Size	400 x 600 mm 800 x 1200 mm 1000 x 1500 mm		Säure Acidity	keine Empfehlung not recommended	keine Empfehlung not recommended	
			Lauge Alkaline	bedingt moderate	bedingt moderate	
Rückseite Back	mit und ohne Boden with and without base		Alterung Aging	bedingt moderate	bedingt moderate	



Bürsteneinsätze für Ringmatten
Brush in set for Ring Matting
Farbe: blau, grün, gelb, rot
Colour: blue, green, yellow, red

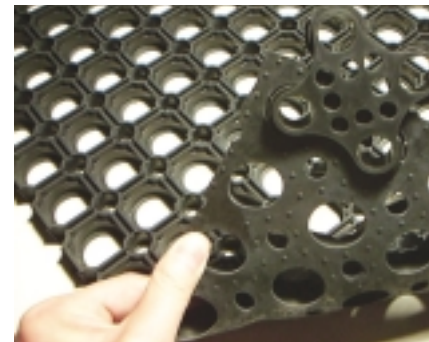

Verbindungsteil für Ringmatten

Connector for Ring Matting



TYP A



TYP B

Marmor-Platten

Marmor Sheetting



blau grau schwarz

Qualität Quality	Spezifisches Gewicht Specific Gravity	Reißfestigkeit Tensile Strength	Reißdehnung Elongation	Härte Hardness	Temperatur Temperature
NBR/SBR	1,40 – 1,45 g/cm ³	ca. 6 MPa	ca. 250 %	70 ± 5 Shore A	ca. - 20 / + 100 °C
Einsatzbereich Application	<ul style="list-style-type: none"> – Küche – Krankenhaus – Laufbahn – Lebensmittelindustrie <ul style="list-style-type: none"> – kitchen – hospital – walking alley – food industry 				
Art. Nr. Art. No.	30T-			Beständigkeit Resistance	
Gesamtstärke Total Thickness	2,0 mm 3,0 mm 4,0 mm	5,0 mm 6,0 mm	Öl Oil	gut good	
Farbe Colour	blau, grau, schwarz blue, grey, black			Treibstoffe Fuel	gut good
Breite Width	1000 mm 1200 mm			Säure Acidity	keine Empfehlung not recommended
Länge Length	10 m			Lauge Alkaline	bedingt moderate
Rückseite Back	stoffgemustert cotton impression			Alterung Aging	bedingt moderate



Hammerschlagmatten/Pferdematten I

Hammerhit Matting/Horse Matting I

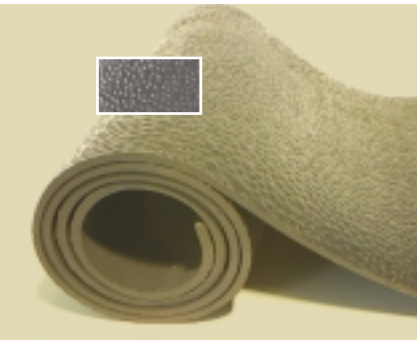

Typ Type	Qualität Quality	Spezifisches Gewicht Specific Gravity	Reißfestigkeit Tensile Strength	Reißdehnung Elongation	Härte Hardness	Temperatur Temperature
A- Standard Standard	NR/SBR	1,40 – 1,50 g/cm ³	ca. 6,0 MPa	ca. 250 %	75 ± 5 Shore A	ca. - 20 / + 70 °C
Einsatzbereich Application	– Vollgummibeläge für Boxen, Laufställe, Waschplätze, Führanlagen, Pferdeanhänger – Rubber flooring for box, stall, wash places, trailer					
Art. Nr. Art. No.	3HSM-				Beständigkeit Resistance	
Stärke Thickness	6,0 mm 8,0 mm 10,0 mm	14,0 mm 18,0 mm 20,0 mm			Öl Oil	bedingt moderate
Einlage Ply	ohne Einlage mit einer Einlage	without ply with 1 ply			Treibstoffe Fuel	bedingt moderate
Farbe Colour	schwarz black					
Breite Width	1000 mm 1200 mm 1400 mm	1500 mm 1650 mm 1800 mm			Säure Acidity	bedingt moderate
Länge Length	10 m 20 m 25 m	30 m 50 m			Lauge Alkaline	bedingt moderate
Rückseite Back	glatt oder stoffgemustert smooth or with cotton impression				Alterung Aging	bedingt moderate

Bds Stoffgemusterte-Matten/Pferdematten II

Matting With Both Sides Cotton Impression/Horse Matting II



Typ Type	Qualität Quality	Spezifisches Gewicht Specific Gravity	Reißfestigkeit Tensile Strength	Reißdehnung Elongation	Härte Hardness	Temperatur Temperature
A- Standard Standard	NR/SBR	1,40 – 1,50 g/cm ³	ca. 6,0 MPa	ca. 250 %	75 ± 5 Shore A	ca. - 20 / + 70 °C
Einsatzbereich Application	– Vollgummibeläge für Boxen, Laufställe, Waschplätze, Führanlagen, Pferdeanhänger – Rubber flooring for box, stall, wash places, trailer					
Art. Nr. Art. No.	3BSM-				Beständigkeit Resistance	
Stärke Thickness	6,0 mm 8,0 mm 10,0 mm	14,0 mm 18,0 mm 20,0 mm			Öl Oil	bedingt moderate
Einlage Ply	ohne Einlage mit einer Einlage	without ply with 1 ply			Treibstoffe Fuel	bedingt moderate
Farbe Colour	schwarz black					
Breite Width	1000 mm 1200 mm 1400 mm	1500 mm 1650 mm 1800 mm			Säure Acidity	bedingt moderate
Länge Length	10 m 20 m 25 m	30 m 50 m			Lauge Alkaline	bedingt moderate
Rückseite Back					Alterung Aging	bedingt moderate

Gummiplatten

Rubber Sheetting

Sonderanfertigungen sind in Breiten ab 1200 mm sowie Längen ab 10 m lieferbar.
Special finish like the width over 1200 mm and the length over 20 m are also available.

A. NR/SBR-Qualität ♦ NR/SBR Quality

Typ Type	Qualität Quality	Spezifisches Gewicht Specific Gravity	Reißfestigkeit Tensile Strength	Reißdehnung Elongation	Härte Hardness	Temperatur Temperature	
A- Standard Standard	NR/SBR	1,50 – 1,60 g/cm ³	ca. 3,8 MPa	ca. 200 %	65 ± 5 Shore A	ca. - 20 / + 70 °C	
B- Weich Soft	NR/SBR	1,40 – 1,50 g/cm ³	ca. 4,5 MPa	ca. 250 %	50 ± 5 Shore A		
C- Hart Hard	NR/SBR	1,40 – 1,50 g/cm ³	ca. 3,8 MPa	ca. 150 %	85 ± 5 Shore A		
Einsatzbereich Application	– für allgemeine industrielle und technische Anwendungen. – for general industrial and technical application						
Art. Nr. Art. No.	5NSS-				Beständigkeit Resistance		
Stärke Thickness	1,0 mm 1,5 mm 2,0 mm 3,0 mm	4,0 mm 5,0 mm 6,0 mm 8,0 mm	10,0 mm 12,0 mm 15,0 mm	20,0 mm 25,0 mm 30,0 mm	40,0 mm 50,0 mm	Öl Oil	keine Empfehlung not recommended
Einlage Ply	ohne Einlage mit einer Einlage mit zwei Einlagen	without ply with 1 ply with 2 plies	ohne without			Treibstoffe Fuel	keine Empfehlung not recommended
Farbe Colour	schwarz black						
Breite Width	1400 mm 1200 mm		1000 mm 1200 mm		Säure Acidity	keine Empfehlung not recommended	
Länge Length	10 m 5 m		10 m 5 m		1 m	Lauge Alkaline	bedingt moderate
Rückseite Back	glatt oder stoffgemustert smooth or with cotton impression				Alterung Aging	bedingt moderate	

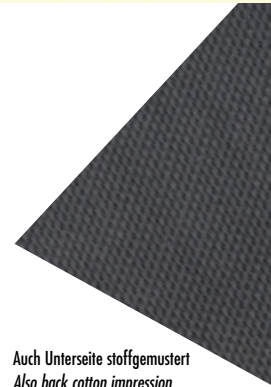
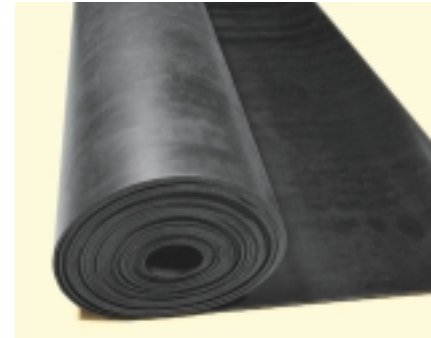

Auch Unterseite stoffgemustert
Also back cotton impression

B. NR/SBR-Qualität mit EP-Einlage ♦ NR/SBR Quality with EP Ply

Typ Type	Qualität Quality	Spezifisches Gewicht Specific Gravity	Reißfestigkeit Tensile Strength	Reißdehnung Elongation	Härte Hardness	Temperatur Temperature	
Gummitteil Rubber Part Gewebe Ply	NR/SBR	1,50 – 1,60 g/cm ³	ca. 7,0 MPa 12 MPa pro Einlage 12 MPa each Ply	ca. 300 %	65 ± 5 Shore A	ca. - 20 / + 70 °C	
Einsatzbereich Application	– Schutzabdeckung oder Trennwand- Vorhänge für Industrie-Lager – protective cover or separate wall curtain for industrial warehouse – Schutzwand für Maschine und Anlage – protective cover for machines						
Art. Nr. Art. No.	5NSS/EP				Beständigkeit Resistance		
Stärke Thickness	3,0 mm 4,0 mm	5,0 mm 6,0 mm				Öl Oil	keine Empfehlung not recommended
Einlage Ply	mit 1 x EP 125 Einlage with 1 EP 125 ply				Treibstoffe Fuel	keine Empfehlung not recommended	
Farbe Colour	schwarz black						
Breite Width	1000 mm 1200 mm				Säure Acidity	keine Empfehlung not recommended	
Länge Length	10 m 21 m 25 m		30 m 50 m		Lauge Alkaline	bedingt moderate	
Rückseite Back	glatt oder stoffgemustert smooth or with cotton impression				Alterung Aging	bedingt moderate	

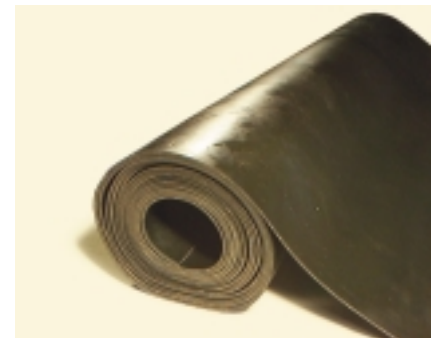

C. Neoprene-Platten, CR/SBR-Qualität ♦ *Rubber Sheeting, CR/SBR Quality*

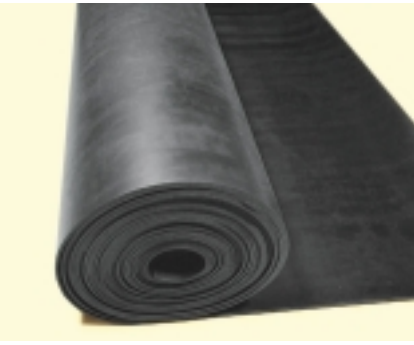

Typ Type	Qualität Quality	Spezifisches Gewicht Specific Gravity	Reißfestigkeit Tensile Strength	Reißdehnung Elongation	Härte Hardness	Temperatur Temperature	
A- Standard Standard	CR/SBR	1,40 – 1,50 g/cm ³	ca. 5,0 MPa	ca. 300 %	65 ± 5 Shore A	ca. - 30 / + 120 °C	
B- Weich Soft	CR/SBR	1,30 – 1,40 g/cm ³	ca. 6,0 MPa	ca. 350 %	50 ± 5 Shore A		
C- Hart Hard	CR/SBR	1,40 – 1,50 g/cm ³	ca. 5,0 MPa	ca. 300 %	85 ± 5 Shore A		
Einsatzbereich Application	– gute Beständigkeit gegen Witterung und Ozon – good resistance against weather and ozone						
Art. Nr. Art. No.	8CRS-				Beständigkeit Resistance		
Stärke Thickness	1,0 mm 1,5 mm 2,0 mm 3,0 mm	4,0 mm 5,0 mm 6,0 mm 8,0 mm	10,0 mm 12,0 mm 15,0 mm	20,0 mm 25,0 mm 30,0 mm	40,0 mm 50,0 mm	Öl Oil	gut good
Einlage Ply	ohne Einlage mit einer Einlage mit zwei Einlagen	without ply with 1 ply with 2 plies	ohne without			Treibstoffe Fuel	keine Empfehlung not recommended
Farbe Colour	schwarz black						
Breite Width	1000 mm 1200 mm	1400 mm		1000 mm 1200 mm		Säure Acidity	bedingt moderate
Länge Length	10 m 5 m			10 m 5 m	1 m	Lauge Alkaline	bedingt moderate
Rückseite Back	glatt smooth					Alterung Aging	gut good

D. Nitril-Platten, NBR/SBR-Qualität ♦ *Rubber Sheeting, NBR/SBR Quality*

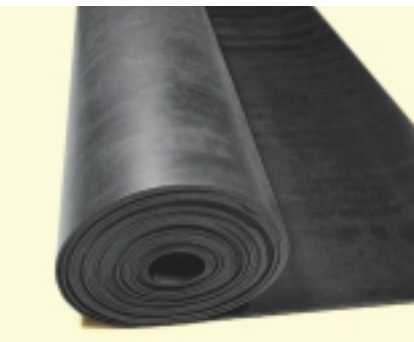

Typ Type	Qualität Quality	Spezifisches Gewicht Specific Gravity	Reißfestigkeit Tensile Strength	Reißdehnung Elongation	Härte Hardness	Temperatur Temperature	
A- Standard Standard	NBR/SBR	1,40 – 1,50 g/cm ³	ca. 5,0 MPa	ca. 250 %	65 ± 5 Shore A	ca. - 20 / + 90 °C	
B- Weich Soft	NBR/SBR	1,40 – 1,50 g/cm ³	ca. 5,0 MPa	ca. 300 %	50 ± 5 Shore A		
C- Hart Hard	NBR/SBR	1,40 – 1,50 g/cm ³	ca. 5,0 MPa	ca. 250 %	85 ± 5 Shore A		
Einsatzbereich Application	– gute Beständigkeit gegen Öl, Benzin und Fett – good resistance against oil, fuel and fat						
Art. Nr. Art. No.	9NBR-				Beständigkeit Resistance		
Stärke Thickness	1,0 mm 1,5 mm 2,0 mm 3,0 mm	4,0 mm 5,0 mm 6,0 mm 8,0 mm	10,0 mm 12,0 mm 15,0 mm	20,0 mm 25,0 mm 30,0 mm	40,0 mm 50,0 mm	Öl Oil	gut good
Einlage Ply	ohne Einlage mit einer Einlage mit zwei Einlagen	without ply with 1 ply with 2 plies	ohne without			Treibstoffe Fuel	gut good
Farbe Colour	schwarz black						
Breite Width	1000 mm 1200 mm	1400 mm		1000 mm 1200 mm		Säure Acidity	bedingt moderate
Länge Length	10 m 5 m			10 m 5 m	1 m	Lauge Alkaline	bedingt moderate
Rückseite Back	glatt smooth					Alterung Aging	keine Empfehlung not recommended

E. EPDM-Platten, EPDM/SBR-Qualität ♦ Rubber Sheeting, EPDM/SBR Quality

Typ Type	Qualität Quality	Spezifisches Gewicht Specific Gravity	Reißfestigkeit Tensile Strength	Reißdehnung Elongation	Härte Hardness	Temperatur Temperature		
A- Standard Standard	EPDM/SBR	1,40 – 1,50 g/cm ³	ca. 6,0 MPa	ca. 300 %	65 ± 5 Shore A	ca. - 30 / + 120 °C		
B- Weich Soft	EPDM/SBR	1,40 – 1,50 g/cm ³	ca. 6,0 MPa	ca. 350 %	50 ± 5 Shore A			
C- Hart Hard	EPDM/SBR	1,40 – 1,50 g/cm ³	ca. 5,5 MPa	ca. 250 %	85 ± 5 Shore A			
Einsatzbereich Application	– gute Beständigkeit gegen Alterung und Witterungs-Ozon – good resistance against aging and weather-ozone							
Art. Nr. Art. No.	10ES-				Beständigkeit Resistance			
Stärke Thickness	1,0 mm 1,5 mm 2,0 mm 3,0 mm	4,0 mm 5,0 mm 6,0 mm 8,0 mm	10,0 mm 12,0 mm 15,0 mm	20,0 mm 25,0 mm 30,0 mm	40,0 mm 50,0 mm	Öl Oil	keine Empfehlung not recommended	
Einlage Ply	ohne Einl. mit einer Einlage mit zwei Einlagen	without ply with 1 ply with 2 plies	ohne without			Treibstoffe Fuel	keine Empfehlung not recommended	
Farbe Colour	schwarz black							
Breite Width	1000 mm 1200 mm	1400 mm	1000 mm 1200 mm			Säure Acidity	gut good	
Länge Length	10 m 5 m	10 m 5 m		1 m			Lauge Alkaline	gut good
Rückseite Back	glatt smooth				Alterung Aging	gut good		

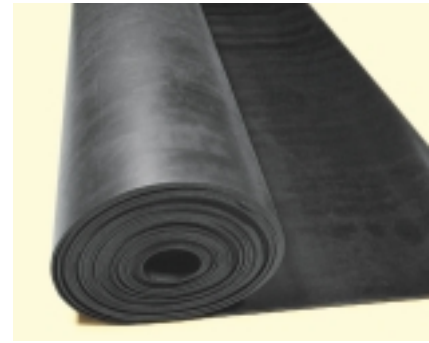

P para-Platten, NR-Qualität Pure Gum Sheeting, NR Quality

Typ Type	Qualität Quality	Spezifisches Gewicht Specific Gravity	Reißfestigkeit Tensile Strength	Reißdehnung Elongation	Härte Hardness	Temperatur Temperature	
A- Grau grey B- Braun brown	NR	1,05 – 1,10 g/cm ³	ca. 18,0 MPa	ca. 600 %	45 ± 5 Shore A	ca. - 30 / + 100 °C	
Einsatzbereich Application	– sehr gute Elastizität für hochanspruchsvolle Anwendung – very good elasticity for highly required application						
Art. Nr. Art. No.	6PR-				Beständigkeit Resistance		
Stärke Thickness	1,0 mm 1,5 mm 2,0 mm 3,0 mm 4,0 mm	5,0 mm 6,0 mm 8,0 mm 10,0 mm	12,0 mm 15,0 mm 20,0 mm 30,0 mm			Öl Oil	keine Empfehlung not recommended
Farbe Colour	grau, braun grey, brown				Treibstoffe Fuel	keine Empfehlung not recommended	
Breite Width	1400 mm				Säure Acidity	gut good	
Länge Length	10 m 5 m				Lauge Alkaline	gut good	
Rückseite Back	glatt smooth				Alterung Aging	gut good	

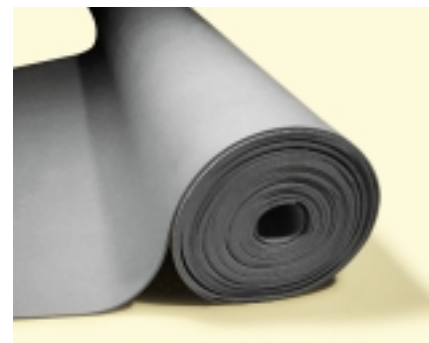
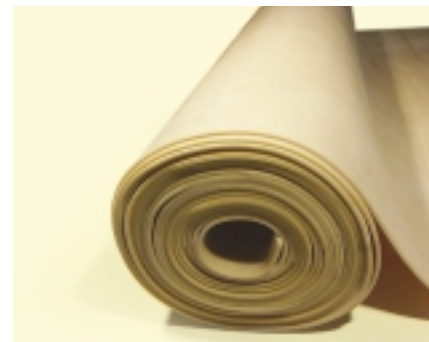

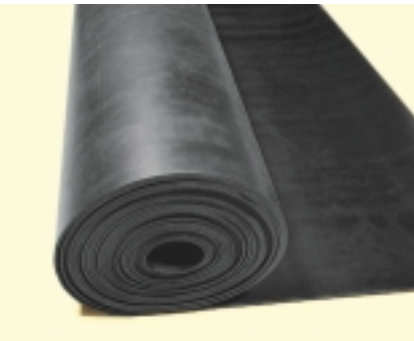
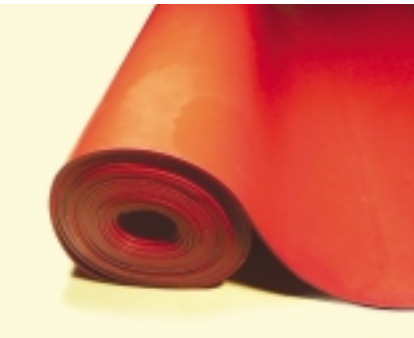

Verschleißschutzplatten, NR-Qualität

Abrasion-Resistant Sheeting, NR Quality

Typ Type	Qualität Quality	Spez. Gewicht Specific Gravity	Reißfestigkeit Tensile Strength	Reißdehnung Elongation	Härte Hardness	Abriebwert Abrasion	Temperatur Temperature
A-rot red	NR	1,10 – 1,15 g/cm ³	ca. 18,0 MPa	ca. 600 %	45 ± 5 Shore A	120 mm ²	ca. - 20 / + 100 °C
B-schwarz black		1,15 – 1,25 g/cm ³	ca. 16,0 MPa	ca. 500 %	60 ± 5 Shore A	130 mm ²	
Einsatzbereich Application	– gute elastische Qualität für die mechanische Beanspruchung – good elastic quality for mechanical application						
Art. Nr. Art. No.	7VR-					Beständigkeit Resistance	
Stärke Thickness	2,0 mm 6,0 mm 15,0 mm 3,0 mm 8,0 mm 20,0 mm 4,0 mm 10,0 mm 30,0 mm 5,0 mm 12,0 mm				Öl Oil	keine Empfehlung not recommended	
Farbe Colour	schwarz, rot black, red				Treibstoffe Fuel	keine Empfehlung not recommended	
Breite Width	1400 mm				Säure Acidity	gut good	
Länge Length	10 m 5 m				Lauge Alkaline	gut good	
Rückseite Back	glatt smooth				Alterung Aging	gut good	

Kombi-Platten, NR-Qualität

Combi-Sheeting, NR Quality



Gummitel Rubber part	Qualität Quality	Spez. Gewicht Specific Gravity	Reißfestigkeit Tensile Strength	Reißdehnung Elongation	Härte Hardness	Abriebwert Abrasion	Temperatur Temperature
rot, grün red, green	NR	1,10 – 1,15 g/cm ³	ca. 18,0 MPa	ca. 600 %	45 ± 5 Shore A	120 mm ²	ca. - 30 / + 100 °C
schwarz black		1,15 – 1,25 g/cm ³	ca. 16,0 MPa	ca. 500 %	60 ± 5 Shore A	130 mm ²	
Einsatzbereich Application	– Schutzabdeckung für Sandstrahlkabine – protective cover for sandblast cabine – Schutzstreifen für Beförderband – protective wall for conveyor belt – Schnee- und Eis-Abwischer für Winterdienstwagen – ice and snow wiper for winter service vehicles						
Art. Nr. Art. No.	11KO-					Beständigkeit Resistance	
Stärke Thickness	10,0 mm 20,0 mm 12,0 mm 30,0 mm 15,0 mm				Öl Oil	keine Empfehlung not recommended	
Farbe Colour	schwarz-grün-schwarz, black-green-black schwarz-rot-schwarz, black-red-black				Treibstoffe Fuel	keine Empfehlung not recommended	
Breite Width	1400 mm				Säure Acidity	bedingt moderate	
Länge Length	10 m 5 m				Lauge Alkaline	bedingt moderate	
Rückseite Back	glatt smooth				Alterung Aging	bedingt moderate	

Gewebetreibriemen

Transmission Belt



Gewebetyp Textile Type	Kante Edge	Reißfestigkeit Tensile Strength
Baumwolle 60 Cotton 60	geschnittene cut; versiegelte wrapped	ca. 6 MPa pro Einl. 6 MPa per layer
Einsatzbereich Application	– Treibriemen für Maschine und Anlage – transmission belt for machine and equipment	
Art. Nr. Art. No.	25TR-	
Einlage Ply	2, 3, 4, 5, 6, 8, 10, 12	
Farbe Colour	gelb, braun yellow, brown	Treibstoffe Fuel
Breite Width	100 mm – 1200 mm	Säure Acidity
Länge Length	50 m, 100 m, 200 m	Lauge Alkaline
		Alterung Aging

EP-Förderband (nach DIN 22102)

EP Conveyor Belt (acc. to DIN 22102)

Typ Type	Qualität Quality	Spezifisches Gewicht Specific Gravity	Reißfestigkeit Tensile Strength	Reißdehnung Elongation	Abrieb Abrasion
Y- Normal Normal	NR	1,20 – 1,25 g/cm ³	20 N/mm ²	400 %	150 mm ³
G- Ölbeständig Oil-Resistant	NBR	1,20 – 1,25 g/cm ³	15 N/mm ²	350 %	250 mm ³
EP-Typ EP Type	Stärke des Deckungsgummis Thickness of Rubber Cover		Einlage Insertion	Breite Width	Länge Length
EP 125 EP 160 EP 200 EP 315 EP 400	Obere Seite Upper	Untere Seite Lower	1 – 5	200 mm – 1600 mm	100 m 200 m
	1 – 8 mm	0 – 5 mm			

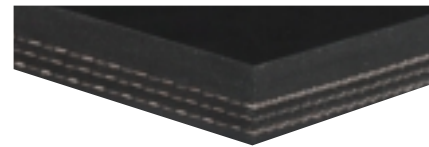

Wellenkanten

Waving Fender

Typ Type	Qualität Quality	Spezifisches Gewicht Specific Gravity	Reißfestigkeit Tensile Strength	Reißdehnung Elongation	Härte Hardness	Temperatur Temperature	
A- Standard Standard	NR/SBR	1,20 – 1,25 g/cm ³	ca. 15,0 MPa	ca. 600 %	70 ± 5 Shore A	ca. - 20 / + 70 °C	
B- Ölbeständig Oil-resistant	NBR/SBR	1,20 – 1,25 g/cm ³	ca. 15,0 MPa	ca. 500 %	70 ± 5 Shore A	ca. - 20 / + 70 °C	
Einsatzbereich Application	– Seitenschutz für Förderband – protective wall for conveyor belt						
Art. Nr. Art. No.	16 WK-			Beständigkeit Resistance			
Farbe Colour	schwarz			Typ A-Standard Type A-Standard	Typ B-Ölbeständig Type B-Oil-resistant		
Höhe (H) Height	40 mm	60 mm	80 mm	120 mm	Öl Oil	keine Empfehlung not recommended	gut good
UB	35 mm	50 mm	50 mm	50 mm	Treibstoffe Fuel	keine Empfehlung not recommended	gut good
WB	30 mm	40 mm	45 mm	45 mm	Säure Acidity	keine Empfehlung not recommended	keine Empfehlung not recommended
WE	35 mm	50 mm	50 mm	50 mm	Lauge Alkaline	bedingt moderate	bedingt moderate
Gewicht kg/m Weight	0,55	1,36	1,58	2,10	Alterung Aging	bedingt moderate	bedingt moderate
Länge Length	50 m						

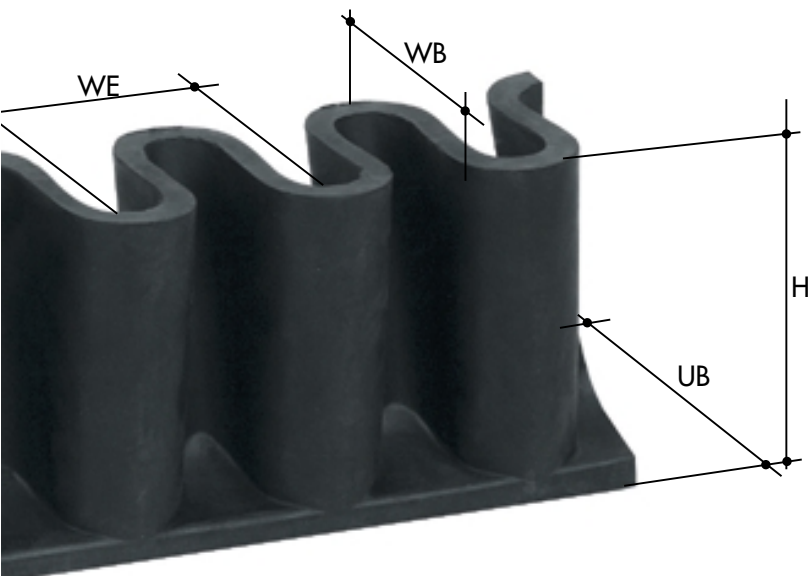
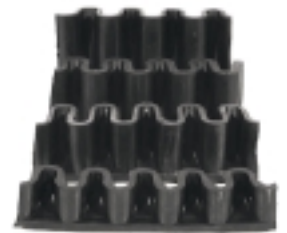

Sonder-Dichtungs-Platten

Special Rubber Sheetting

A. Hypalon-Platten, CSM-Qualität ♦ Hypalon Sheetting, CSM Quality

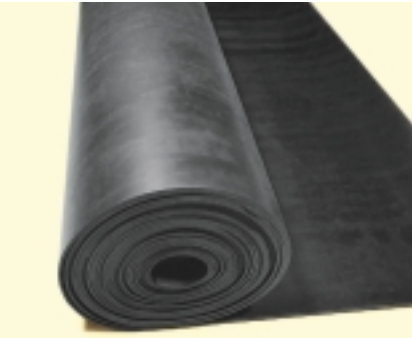

Qualität Quality	Spezifisches Gewicht Specific Gravity	Reißfestigkeit Tensile Strength	Reißdehnung Elongation	Härte Hardness	Temperatur Temperature
CSM	1,25 – 1,30 g/cm ³	ca. 6,5 MPa	ca. 350 %	60 ± 5 Shore A	ca. - 50 / + 200 °C
Einsatzbereich Application	– sehr gute Beständigkeit gegen Säuren, Laugen und Alterung – Einsatz bei niedrigen und hohen Temperaturen – very high resistance against acidity, alkaline and aging – application in low and high temperature				
Art. Nr. Art. No.	12 HYS-			Beständigkeit Resistance	
Stärke Thickness	1,0 mm 1,5 mm 2,0 mm 3,0 mm	4,0 mm 5,0 mm 6,0 mm 8,0 mm	10,0 mm 12,0 mm 15,0 mm 20,0 mm	Öl Oil	keine Empfehlung not recommended
Farbe Colour	schwarz black			Treibstoffe Fuel	bedingt moderate
Breite Width	1000 mm 1200 mm			Säure Acidity	gut good
Länge Length	10 m 5 m			Lauge Alkaline	gut good
Rückseite Back	glatt smooth			Alterung Aging	sehr gut very good

B. Silikon-Platten, Silikon-Qualität ♦ Silicon Sheetting, Silicon Quality

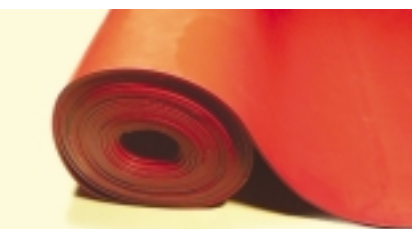

Type Type	Qualität Quality	Spezifisches Gewicht Specific Gravity	Reißfestigkeit Tensile Strength	Reißdehnung Elongation	Härte Hardness	Temperatur Temperature
A-transparent transparent B-rot red	Silikon	1,25 – 1,30 g/cm ³ 1,25 – 1,30 g/cm ³	ca. 6,5 MPa ca. 6,0 MPa	ca. 350 % ca. 350 %	ca. 60 ± 5 Shore A ca. 60 ± 5 Shore A	ca. - 50 / + 200 °C ca. - 60 / + 220 °C
Einsatzbereich Application	– sehr gute Beständigkeit gegen Säuren, Laugen und Alterung – Einsatz bei niedrigen und hohen Temperaturen – very high resistance against acidity, alkaline and aging – application in low and high temperature					
Art. Nr. Art. No.	17 SIL-			Beständigkeit Resistance		
Stärke Thickness	1,0 mm 1,5 mm 2,0 mm 3,0 mm	4,0 mm 5,0 mm 6,0 mm		Öl Oil	bedingt moderate	
Farbe Colour	transparent, rot transparent, red			Treibstoffe Fuel	bedingt moderate	
Breite Width	1000 mm 1200 mm			Säure Acidity	gut good	
Länge Length	10 m			Lauge Alkaline	gut good	
Rückseite Back	glatt smooth			Alterung Aging	sehr gut very good	

C. FPM-Platten, FPM-Qualität ♦ FPM Sheetting, FPM Quality

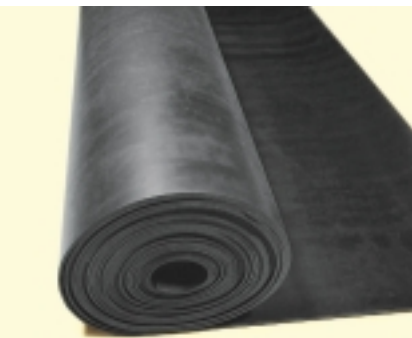

Qualität Quality	Spezifisches Gewicht Specific Gravity	Reißfestigkeit Tensile Strength	Reißdehnung Elongation	Härte Hardness	Temperatur Temperature
FPM	1,80 – 2,0 g/cm ³	ca. 7,0 MPa	ca. 300 %	ca. 70 ± 5 Shore A	ca. - 10 / + 200 °C
Einsatzbereich Application	– sehr gute Beständigkeit gegen Öl, Benzin, Säuren, Laugen und Alterung – very high resistance against oil, fuel, acidity, alkaline and aging				
Art. Nr. Art. No.	18 FPM-			Beständigkeit Resistance	
Stärke Thickness	1,0 mm, 1,5 mm, 2,0 mm, 3,0 mm, 4,0 mm, 5,0 mm, 6,0 mm,			Öl Oil	sehr gut very good
Farbe Colour	schwarz black			Treibstoffe Fuel	sehr gut very good
Breite Width	1000 mm 1200 mm			Säure Acidity	sehr gut very good
Länge Length	10 m			Lauge Alkaline	sehr gut very good
Rückseite Back	glatt smooth			Alterung Aging	sehr gut very good

Rampenpuffer

Rubber Bumper

NR/SBR-Qual., mit Stahlscheiben und/oder Hülsen, ca. 70 Sh.



1. Höhe 60 mm und 80 mm mit 2 Löchern, Länge 200 mm

Art. Nr.	Höhe	Breite	Länge	Lochzahl	Lochabstand
21R60-200	60 mm	52 mm	200 mm	2	120 mm
21R80-200	80 mm	52 mm	200 mm	2	120 mm



2. Höhe 60 mm und 80 mm mit 3 Löchern, Länge 300 mm

Art. Nr.	Höhe	Breite	Länge	Lochzahl	Lochabstand
21R60-300	60 mm	52 mm	300 mm	3	115 mm
21R80-300	80 mm	52 mm	300 mm	3	115 mm



3. Höhe 60 mm und 80 mm mit 3 Löchern, Länge 400 mm

Art. Nr.	Höhe	Breite	Länge	Lochzahl	Lochabstand
21R60-400	60 mm	52 mm	400 mm	3	165 mm
21R80-400	80 mm	52 mm	400 mm	3	165 mm

4. Höhe 35 mm mit 4 Löchern, Länge 530 mm

Art. Nr.	Höhe	Breite	Länge	Lochzahl	Lochabstand
21R35-530	35 mm	60 mm	530 mm	4	157 mm

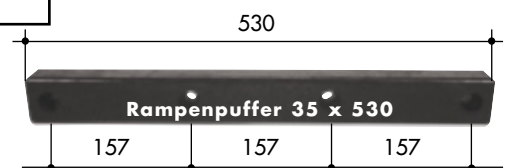

5. Höhe 50 mm mit 2 Löchern, Länge 125 mm

Art. Nr.	Höhe	Breite	Länge	Lochzahl	Lochabstand
21R50-125	50 mm	43 mm	125 mm	2	60 mm

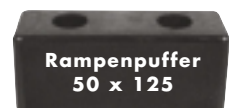

6. Höhe 80 mm mit 4 Löchern, Länge 200 mm

Art. Nr.	Höhe	Breite	Länge	Lochzahl
21R80-150	80 mm	150 mm	200 mm	4

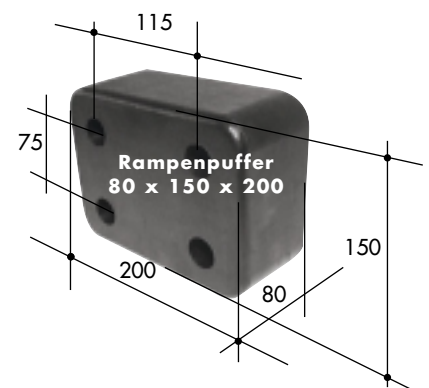

7. Höhe 150/75 mm mit 2 Löchern, Länge 250 mm

Art. Nr.	Höhe	Breite	Länge	Lochzahl	Lochabstand
21R80-150	150/75 mm	90 mm	250 mm	2	150 mm

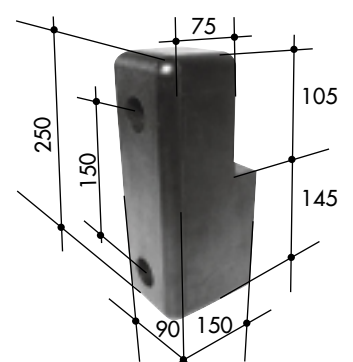

Standard-Formteile

Standard Moulded Articles



Art.-Nr.	Warenbeschreibung Description	Abmessung Size	Gewicht/St. Weight/Pc	Härte Hardness	Farbe Colour
12.0-	Plattenlegerhammer, Floor tiler hammer -eckig, square -rund, round	100 x 100 mm ø 100 mm	1600 g	90 Sh.	schwarz black
12.1-	Gummihammer nach DIN 5128, Rubber Mallet -mit 2 flachen Köpfen, 2 Flat Heads -mit 1 runden Kopf, 1 Ball Head -ohne Stiel, without Handle -mit Stiel, with Handle	40 x 80 mm 54 x 90 mm 64 x 113 mm 74 x 127 mm 90 x 138 mm	110 g 230 g 400 g 630 g 1000 g	90 Sh. 70 Sh.	schwarz black weiß white
12.2-	Gipsbecher Plaster Cup	127 x 90 mm 135 x 50 mm 165 x 65 mm	140 g 240 g 360 g	65 Sh.	schwarz black rot red
12.3-	Schleiftelle Grinding Disc	125 mm 150 mm	115 g 180 g	70 Sh.	schwarz black
12.4-	Manometerschutzkappen Manometer Cap	63 mm 100 mm	38 g 80 g	60 Sh.	rot, blau, gelb, schwarz red, blue, yellow, black
12.5-	Ausgüßreiniger, WC Cleaner	110 mm	190 g	60 Sh.	rot red
12.6-	-ohne Stiel, without Handle -mit Stiel, with Handle	130 mm	250 g		
12.7-	Hammeraufsatz Hammer Cover -1,0; 1,25; 1,50; 2,0 kg	72 x 72 mm	320 g	70 Sh.	schwarz black
12.8-	Haubenhalter Bonnet Clamp	123 x 26 mm 123 x 32 mm	55 g 60 g	65 Sh.	schwarz black
12.9-	Fugengummi Rubber Brush	60 x 200 mm 60 x 300 mm	158 g 215 g		schwarz black
12.10-	Knieschoner, Guard Protector -auch Schaumgummi, Sponge	160 x 70 mm	520 g	50 Sh. 40 Sh.	schwarz black
12.11-	Sandpapierhalter Sandpaper Holder	120 x 67 mm	300 g	65 + 90 Sh.	schwarz black
12.12-	Türstopper Door Stopper	22 x 10 mm 30 x 26 mm 40 x 25 mm 40 x 35 mm	5 g 25 g 40 g 55 g	60 Sh.	schwarz black rot red grau grey
12.13-	Gummistopfen	43 x 52 x 40 mm	90 g	45 Sh.	schwarz black

Alle Gewichtsangaben sind mit $\pm 10\%$ Toleranz zu rechnen.
 $\pm 10\%$ tolerance in weight are allowed.

Gummiformteile können nach Zeichnungen oder Mustern von uns
nachgefertigt werden.
Rubber moulded articles could be made acc. to drawings or samples.

Gummiherstellung



Sinoda

Industriegummi GmbH

Max-Planck-Str. 11
D-63128 Dietzenbach
Germany

Tel.: +49 (0) 60 74-4 00 74-0

Fax: +49 (0) 60 74-4 00 74-98

E-Mail: info@sinoda.de

Internet: www.sinoda.de